

# FEKABOX 200

AUTOMATIC PUMPING STATION FOR 1 PUMP



## TECHNICAL DATA

**Operating range:** from 1 to 24 m<sup>3</sup>/h with a head of up to 15 mt.

**Pumped liquid:** ground water, rain water, clear waste water, black waste water and water from rivers and lakes.

**Maximum liquid temperature range:** 45°C

**Installation:** Inside or outside the building. Laid on the floor, under the ground or housed.

Not suitable for vehicles but walkable up to 100 Kg.

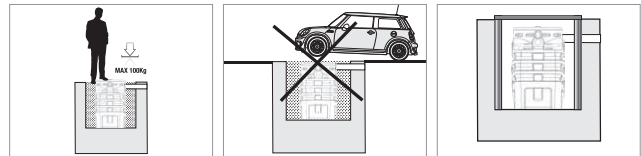

## APPLICATIONS

Pump station useful for the collection and transport in sewer of domestic waste water (sewage, rainwater and gray water), from basements or garages of one or more housing units, when the drainage system can not be achieved by gravity.

## CONSTRUCTIVE CHARACTERISTICS

**CAPACITY:** 200 lt

**MATERIAL:** LLDPE

**REGULATIONS:** 12050-1

**CONNECTIONS:**

- Input DN 50/110
- Ventilation DN 50
- Output G2"

**COMPONENTS INCLUDED:**

- A lifting device 2" PP and anti-rotation bracket for FEKA VS e VX
- Cable gland for single pump
- Connection 2" F x 1 x 1/4 M for FEKA 600
- Floating cable clamp kit FEKA VS e VX

**COMPONENTS EXCLUDED:**

- Pump: to be selected according to the configuration possibilities
- Floatin alarm support

## PUMP INSTALLATION

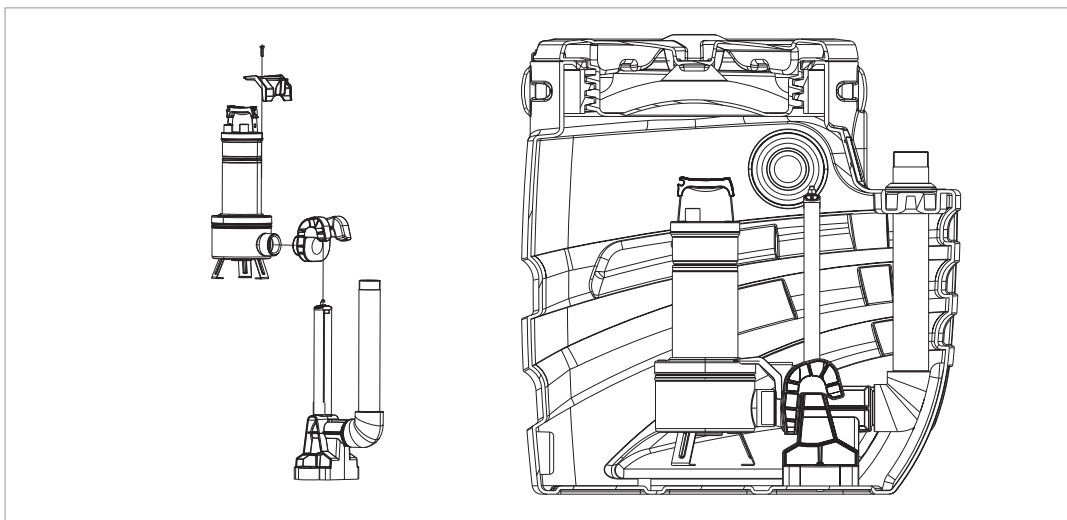

# FEKABOX 200 - WASTE WATER COLLECTION AND LIFTING

Maximum liquid temperature range: 45°C

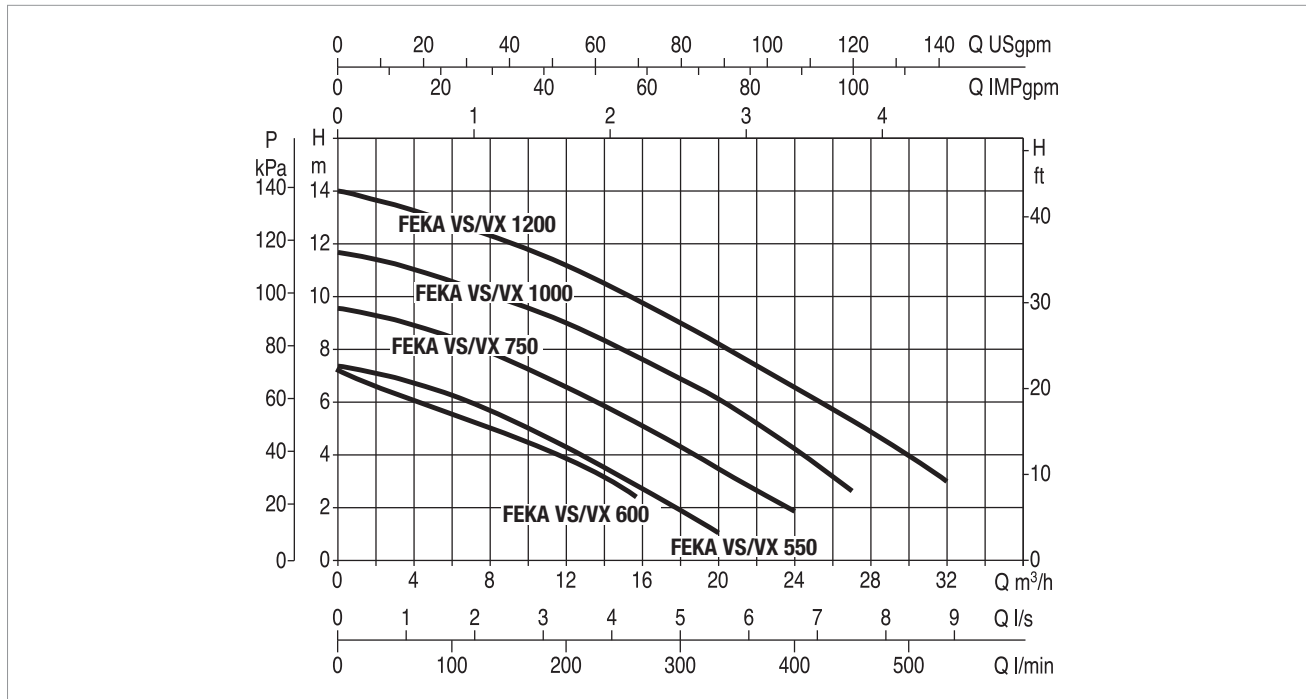

## CONFIGURATION

PUMP MODEL	ELECTRICAL DATA				
	VOLTAGE 50 HZ	P1 MAX kW	P2 NOMINAL		In A
			kW	HP	
FEKA 600 M-A	1X220-240 V~	1	0,55	0,75	4,3
FEKA VS/VX 550 M-A	1X220 - 240 V~	0,9	0,55	0,75	4,2
FEKA VS/VX 750 M-A	1X220 - 240 V~	1,1	0,75	1	5,13
FEKA VS/VX 1000 M-A	1X220 - 240 V~	1,4	1	1,36	6,63
FEKA VS/VX 1200 M-A	1X220 - 240 V~	1,9	1,2	1,6	8,63

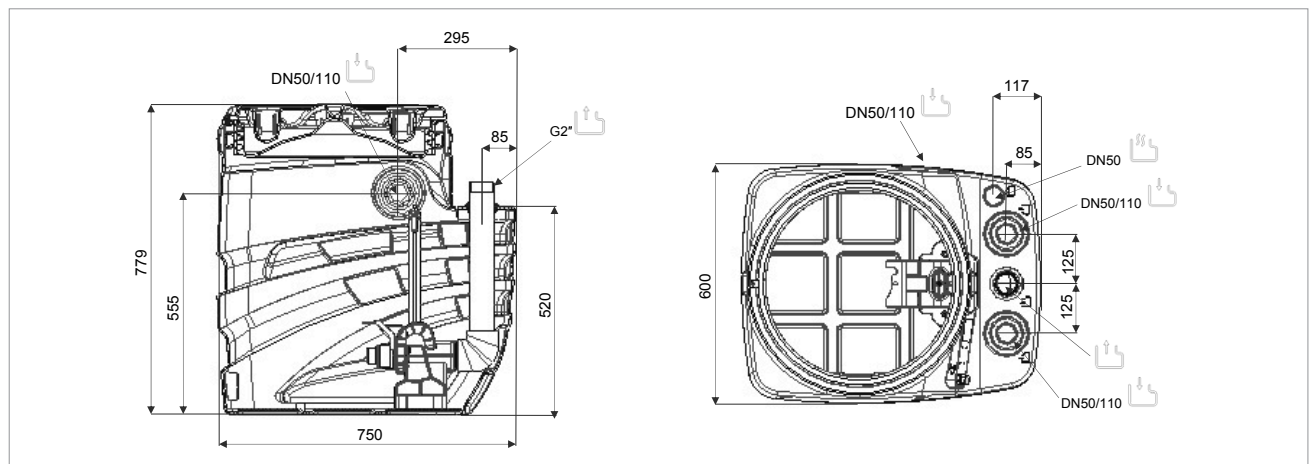

## DIMENSIONS AND WEIGHTS

PACKAGING DIMENSIONS			WEIGHT Kg
L/A	L/B	H	
750	600	779	23,2

### LEGEND:

- Connection of delivery pipe or emergency outlet
- Collection pipe inlet
- Outlet of power cables and float cables
- Connection of ventilation pipe
- Recyclable material